

# Aerospace Rings (Metric)

## XES Series

### Stock items available in:

- Carbon steel
- 302 and 316 stainless steel

MA 4016<sup>4</sup>

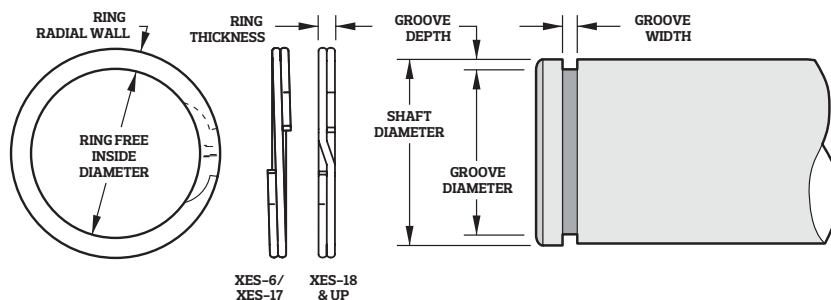

\* No Removal Notch

Part No. <sup>1</sup>	Shaft Diameter	Ring			Groove		Thrust Capacity	
		Inside Diameter	Radial Wall	Thickness	Diameter	Width	Groove Yield (N) <sup>2</sup>	Ring Shear (N) <sup>3</sup>
XES-6*	6,00	5,61	0,38 - 0,58	0,64	5,66	0,74	500	3160
XES-7*	7,00	6,53	0,51 - 0,71	0,64	6,58	0,74	720	3690
XES-8*	8,00	7,49	0,51 - 0,71	0,64	7,57	0,74	840	4210
XES-9*	9,00	8,41	0,64 - 0,84	0,64	8,48	0,74	1140	4740
XES-10*	10,00	9,40	0,64 - 0,84	0,64	9,50	0,74	1220	5270
XES-11	11,00	10,39	0,76 - 0,96	0,64	10,46	0,74	1450	5790
XES-12	12,00	11,18	1,02 - 1,22	0,60	11,29	0,70	2100	7950
XES-13	13,00	12,13	1,14 - 1,35	0,89	12,24	1,00	2410	12100
XES-14	14,00	13,06	1,14 - 1,35	0,89	13,19	1,00	2800	13040
XES-15	15,00	13,98	1,14 - 1,35	0,89	14,09	1,00	3360	13970
XES-16	16,00	14,90	1,27 - 1,48	0,89	15,02	1,00	3820	14900
XES-17	17,00	15,82	1,27 - 1,48	0,89	16,02	1,00	4060	15830
XES-18	18,00	16,80	1,52 - 1,73	1,07	16,92	1,20	4730	20150
XES-19	19,00	17,73	1,52 - 1,73	1,07	17,87	1,20	5270	21270
XES-20	20,00	18,62	1,52 - 1,73	1,07	18,77	1,20	6040	22390
XES-21	21,00	19,57	1,52 - 1,73	1,07	19,72	1,20	6550	23510
XES-22	22,00	20,45	1,78 - 1,98	1,07	20,62	1,20	7390	24630
XES-23	23,00	21,39	1,78 - 1,98	1,07	21,57	1,20	8070	25750
XES-24	24,00	22,35	1,78 - 1,98	1,07	22,52	1,20	8650	26870
XES-25	25,00	23,25	2,03 - 2,24	1,07	23,42	1,20	9620	27990
XES-26	26,00	24,21	2,03 - 2,24	1,07	24,42	1,20	10000	29110
XES-27	27,00	25,04	2,49 - 2,69	1,27	25,35	1,40	10910	31170
XES-28	28,00	26,00	2,49 - 2,69	1,27	26,30	1,40	11590	32330
XES-29	29,00	26,95	2,49 - 2,69	1,27	27,27	1,40	12290	33480
XES-30	30,00	27,92	2,49 - 2,69	1,27	28,25	1,40	12860	34640
XES-31	31,00	28,84	2,49 - 2,69	1,27	29,17	1,40	13890	35790
XES-32	32,00	29,77	2,49 - 2,69	1,27	30,09	1,40	14960	36950
XES-34	34,00	31,54	2,87 - 3,07	1,27	31,90	1,40	17390	39260
XES-35	35,00	32,44	2,87 - 3,07	1,27	32,80	1,40	18750	40410
XES-36	36,00	33,40	2,87 - 3,07	1,27	33,75	1,40	19810	41560
XES-37	37,00	34,24	2,87 - 3,07	1,27	34,67	1,40	21080	42720
XES-38	38,00	35,18	2,87 - 3,07	1,27	35,66	1,40	21650	43870
XES-40	40,00	37,15	3,12 - 3,33	1,57	37,55	1,75	23960	57090
XES-42	42,00	39,02	3,12 - 3,33	1,57	39,45	1,75	26180	59990
XES-45	45,00	41,77	3,12 - 3,33	1,57	42,25	1,75	30240	64230
XES-46	46,00	42,67	3,12 - 3,33	1,57	43,15	1,75	32040	65660
XES-47	47,00	43,81	3,89 - 4,09	1,57	44,31	1,75	30900	67080
XES-48	48,00	44,48	3,89 - 4,09	1,57	45,05	1,75	34600	68510
XES-50	50,00	46,69	3,89 - 4,09	1,57	47,05	1,75	36040	71370
XES-52	52,00	49,62	3,12 - 3,33	1,25	50,15	1,42	23550	59090
XES-53	53,00	50,62	3,12 - 3,33	1,25	51,15	1,42	24000	60230
XES-54	54,00	51,62	3,12 - 3,33	1,25	52,15	1,42	24460	61370
XES-55	55,00	52,62	3,38 - 3,58	1,25	53,15	1,42	24910	62500
XES-56	56,00	53,62	3,38 - 3,58	1,25	54,15	1,42	25370	63640
XES-58	58,00	55,43	3,38 - 3,58	1,25	56,01	1,42	28250	65910
XES-59	59,00	56,43	3,38 - 3,58	1,25	57,01	1,42	28730	67050

<sup>1</sup> Add suffix "-S02" for 302 stainless steel, "-S16" for 316 stainless steel. <sup>2</sup> Based on a groove material yield strength of 310 N/mm<sup>2</sup> and a safety factor of 2. <sup>3</sup> Based on a safety factor of 3. <sup>4</sup> Contact TFC for details/information on how to order parts to be in compliance with this specification.

# Aerospace Rings (Metric)

## XES Series

Metric (mm)	Part No. <sup>1</sup>	Shaft Diameter	Ring			Groove			Thrust Capacity	
			Inside Diameter	Radial Wall	Thickness	Diameter	Width	Groove Yield (N) <sup>2</sup>	Ring Shear (N) <sup>3</sup>	
	XES-60	60,00	57,43	3,38 - 3,58	1,25	58,01	1,42	29220	68180	
	XES-61	61,00	58,36	3,38 - 3,58	1,25	58,91	1,42	31190	69320	
	XES-62	62,00	59,30	3,63 - 3,84	1,25	59,91	1,42	31710	70460	
	XES-63	63,00	60,30	3,63 - 3,84	1,25	60,91	1,42	32220	71590	
	XES-64	64,00	61,25	3,63 - 3,84	1,25	61,91	1,42	32730	72730	
	XES-65	65,00	62,20	3,63 - 3,84	1,25	62,81	1,42	34820	73870	
	XES-66	66,00	63,16	3,63 - 3,84	1,25	63,79	1,42	35680	75000	
	XES-67	67,00	64,16	3,63 - 3,84	1,25	64,71	1,42	37530	76140	
	XES-68	68,00	65,08	3,89 - 4,09	1,25	65,71	1,42	38090	77270	
	XES-69	69,00	66,06	3,89 - 4,09	1,25	66,71	1,42	38650	78410	
	XES-70	70,00	67,08	3,89 - 4,09	1,25	67,71	1,42	39210	79550	
	XES-71	71,00	68,04	3,89 - 4,09	1,25	68,71	1,42	39770	80680	
	XES-72	72,00	69,00	4,11 - 4,37	1,25	69,65	1,42	41380	81820	
	XES-75	75,00	71,93	4,11 - 4,37	1,25	72,61	1,42	43830	85230	
	XES-78	78,00	74,84	4,11 - 4,37	1,55	75,55	1,73	46730	109910	
	XES-80	80,00	76,80	4,37 - 4,62	1,55	77,51	1,73	48700	112730	
	XES-82	82,00	78,72	4,37 - 4,62	1,55	79,45	1,73	51120	115550	
	XES-85	85,00	81,62	4,62 - 4,88	1,55	82,35	1,73	55060	119780	
	XES-88	88,00	84,53	4,62 - 4,88	1,55	85,31	1,73	57860	124000	
	XES-90	90,00	86,43	4,88 - 5,13	1,55	87,21	1,73	61370	126820	
	XES-95	95,00	91,37	4,88 - 5,13	1,55	92,15	1,73	66160	133870	
	XES-100	100,00	96,10	5,13 - 5,38	1,55	97,01	1,73	73050	140910	
	XES-105	105,00	100,94	5,38 - 5,64	1,55	101,85	1,73	80780	147960	
	XES-110	110,00	105,75	5,64 - 5,89	1,55	106,69	1,73	88930	155000	
	XES-115	115,00	110,59	5,89 - 6,15	1,55	111,55	1,73	96890	162050	
	XES-120	120,00	115,49	6,20 - 6,45	1,83	116,45	2,00	104030	199640	
	XES-125	125,00	120,44	6,20 - 6,45	1,83	121,45	2,00	108360	207960	
	XES-130	130,00	125,34	6,20 - 6,45	1,83	126,35	2,00	115860	216280	
	XES-135	135,00	130,20	6,20 - 6,45	1,83	131,27	2,00	122950	224600	
	XES-140	140,00	135,14	6,20 - 6,45	1,83	136,25	2,00	128190	232920	
	XES-145	145,00	140,00	6,20 - 6,45	1,83	141,17	2,00	135590	241230	
	XES-150	150,00	145,00	6,20 - 6,45	1,83	146,17	2,00	140260	249550	
	XES-155	155,00	149,33	7,72 - 8,03	2,18	150,60	2,40	166080	307190	
	XES-160	160,00	154,31	7,72 - 8,03	2,18	155,60	2,40	171430	317100	
	XES-165	165,00	159,23	7,72 - 8,03	2,18	160,60	2,40	176790	327010	
	XES-170	170,00	164,00	7,72 - 8,03	2,18	165,40	2,40	190430	336920	
	XES-175	175,00	169,00	7,72 - 8,03	2,18	170,40	2,40	196030	346830	
	XES-180	180,00	173,78	7,72 - 8,03	2,18	175,20	2,40	210400	356740	
	XES-185	185,00	178,70	7,72 - 8,03	2,18	180,20	2,40	216240	366650	
	XES-190	190,00	183,70	7,72 - 8,03	2,18	185,20	2,40	220080	376560	
	XES-195	195,00	188,43	7,72 - 8,03	2,18	190,00	2,40	237420	386460	
	XES-200	200,00	193,43	7,72 - 8,03	2,18	195,00	2,40	243510	396370	
	XES-210	210,00	202,93	9,32 - 9,63	2,18	204,60	2,40	276140	416190	
	XES-220	220,00	212,65	9,32 - 9,63	2,18	214,40	2,40	300010	436010	
	XES-230	230,00	222,60	9,32 - 9,63	2,18	224,40	2,40	313640	455830	
	XES-240	240,00	232,32	9,32 - 9,63	2,18	234,20	2,40	328970	475650	
	XES-250	250,00	241,83	9,32 - 9,63	2,18	243,80	2,40	377440	495470	
	XES-260	260,00	251,57	9,32 - 9,63	2,18	253,60	2,40	405210	515290	
	XES-270	270,00	261,30	9,32 - 9,63	2,18	263,40	2,40	433940	535100	
	XES-280	280,00	271,04	9,32 - 9,63	2,18	273,20	2,40	463650	554920	

<sup>1</sup> Add suffix "-S02" for 302 stainless steel, "-S16" for 316 stainless steel. <sup>2</sup> Based on a groove material yield strength of 310 N/mm<sup>2</sup> and a safety factor of 2. <sup>3</sup> Based on a safety factor of 3. <sup>4</sup> Contact TFC for details/information on how to order parts to be in compliance with this specification.